

LC Connector Product Specification

Section 2: Adapters

LC Connector Product Specification

General Definition:

The LC Connector Product is a robust optical connector designed to support Telecom and Datacom networks. The connector family includes but not limited to Jumper Connectors, Behind the Wall connectors (BTW), Adapters, Attenuators, Jumpers and an assortment of connector modules and panels. The connector is defined as the plug portion equipped with a tunable cylindrical ferrule while incorporating unique trigger and latch features. The LC Connector family provides a size reduction relative to traditional connectors, which has coined the term Small Form Factor connectors (SFF). SFF connectors are typically 50% smaller than standard SC and ST fiber products. The LC was designed to be a high performance SFF incorporating traditional technology, advances in latching systems, and versatile enough for both singlemode and multimode fiber applications.

Terms of Specification:

The specification document is intended to provide users of Yazaki LC Connector products a level of confidence and means of understanding the characteristics of purchased product. The product is designed and intended to be manufactured according to the specification document. The product specification is a fluid document, which is only a guideline as to the features and performance of the product, which are subject to change without notice.

Definition of Products:

LC 1.5 to 2.0 mm Unibody Connectors for jumpers: Robust connectors designed to mount onto 1.5 to 2.0 mm fiber cordage and intended to meet the Telcordia specification GR326 Type I Media (~3.0mm). Note that exceptions are made based on smaller size and future changes within GR326 for SFF connectors; however, the Unibody connector was designed to meet Section 4.3.5 Transmission with Applied Load for 3.0 mm cord. Simplex and duplex are available.

LC 3.0 mm Unibody Connectors for jumpers: Robust connectors designed to mount onto 3.0 mm fiber cordage and intended to meet the Bellcore/Telcordia specification GR326 Type I Media (~3.0mm). Note that exceptions are made based on smaller size and future changes within GR326 for SFF connectors; however, the Unibody connector was designed to meet Section 4.3.5 Transmission with Applied Load for 3.0 mm cord. Simplex and duplex are available.

LC BTW Connectors: Shorter LC connectors designed for 0.9 mm buffered fiber. This product is intended to meet Telcordia specification GR326 Type II Media (0.9 mm).

LC BTW Unibody Connectors: Robust connectors based on the Unibody connector and equipped to mount onto 0.9 mm buffered fiber and intended to meet the Telcordia specification GR326 Type II Media (0.9 mm). A unique feature; this simplex BTW connector is duplexable!

LC Patchcords (Jumpers): Connectorized with 1.5, 1.6, 2.0 or 3.0 mm cordage in various lengths and fiber counts. Jumpers are produced in a vast array of hybrid configurations allowing interconnection between LC based product and other connector styles. These products are intended to meet Telcordia specification GR326 Type I Media.

LC Adapters: Two sided port configuration, which holds two LC connectors while providing the alignment mechanism for the cylindrical ferrules. Adapters are designed in simplex, duplex and can be ganged for higher density configurations based on application needs.

LC Attenuators: Fixed plug-in style optical attenuators are available in 1-dB steps from 0 to 20 dB, plus 25-dB. These doped-fiber based attenuators are spectrally flat over the 1260 to 1610 nm wavelength range and have precise values. Special values and tolerancing are available on request. Attenuator products are designed to plug into any standard LC adapter. The design is structured from a connector front and a simplex receptacle rear portion, and they are capable of +30 dBm (1W).

Product Identification:

LC products are easy to identify in accordance with industry standard colors:

- Blue represents Singlemode
- Beige represents Multimode
- Green represents Singlemode 8° Angled End Faces
- Our LC Products meet these Standards:
 - ⇒ TIA 568 for A & B port identification on duplex adapters and connectors
 - ⇒ TIA/EIA-604-10A, FOCIS 10 Fiber Optic Connector Intermateability Standard – Type LC
 - ⇒ Fibre Channel Physical Interfaces (Physical Interface 11) for LC
 - ⇒ IEC 61754-20 (2002-08) Fibre Optic Connector Interfaces – Part 20: Type LC Connector Family

Additional Sections of LC Product Specification:

- Connectors: Section 1, Doc. No. OCD-EE-401-1
- Patchcords : Section 3, Doc. No. OCD-EE-401-3 (insertion/removal tool)
- Attenuators: Section 4, Doc. No. OCD-EE-401-4
- Environmental & Physical Section 5, Doc. No. OCD-EE-401-5
Performance Results:

Table of Contents

2. LC Connector Product – Adapter Specification.....	
2.1 LC Duplex Adapters (Perspective View)	4
2.2 LC Adapter Footprint Dimensions	5
2.3 Panel Cutout Dimensions for Mounting LC Adapters	6
2.4 LC Adapter Materials	7
2.5 LC Adapter Specifications for Intermateability	7-10
2.6 LC Duplex Adapter Specifications for Intermateability	11
2.7 LC Adapter Mounting Options	11
2.8 LC Adapter Part Identification	12
2.9 LC Adapter Color Coding	12
2.10 LC Adapter Inspection Gauge	13

2.0 - LC Adapter Product Specification

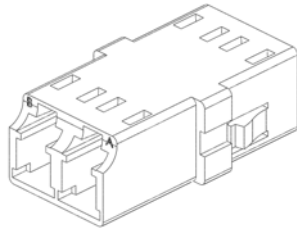

2.1a – Duplex SlimLine Adapter

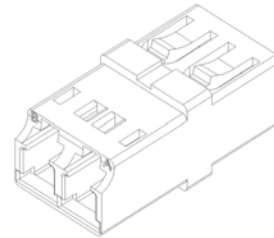

2.1b - Duplex SlimLine Adapter, Vertical Flange-VF

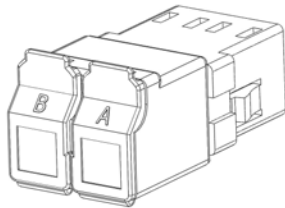

2.1c – Duplex SlimLine with Dust Shutter

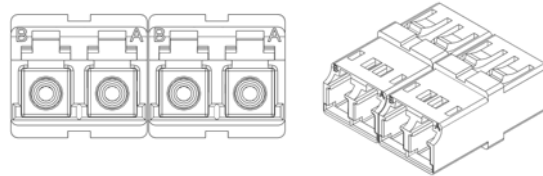

2.1d - Quad SlimLine assembled from 2 SlimLine-VF side-by-side

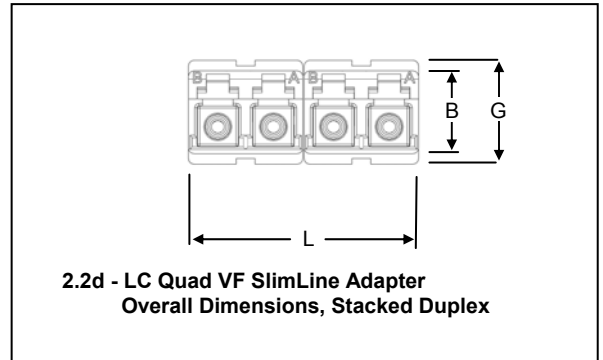
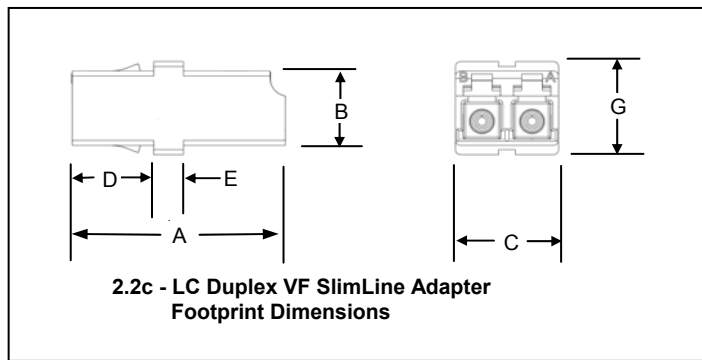
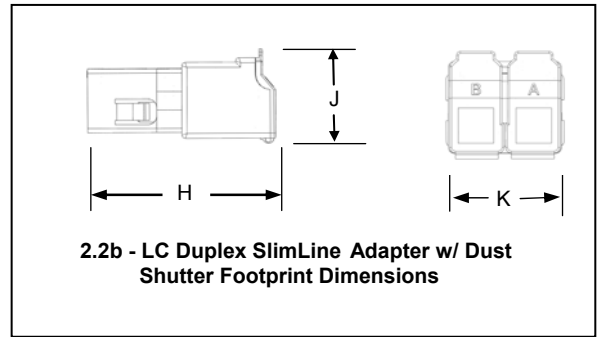
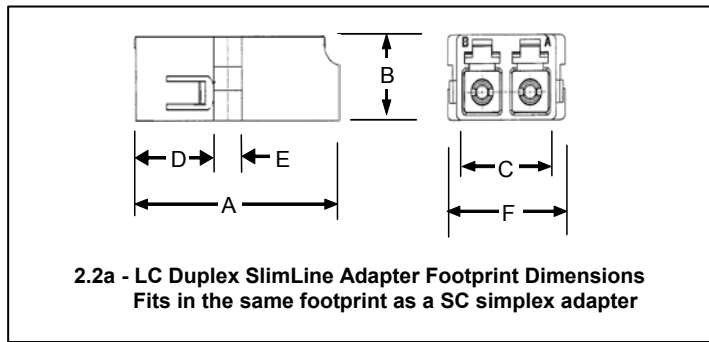

DIMENSION	Minimum (mm)	Maximum (mm)	Comments
A	26.6	26.8	
B	9.35	9.45	
C	12.8	12.9	
D	10.15	10.25	
E	3.66	3.76	
F	15.24	15.34	
G	11.69	11.79	
H	27.75	28.05	
J	14.15	14.25	
K	14.45	14.65	
L	25.6	25.8	Quad (VF only)

2.3 - Panel Cutout Dimensions for Mounting LC Adapters

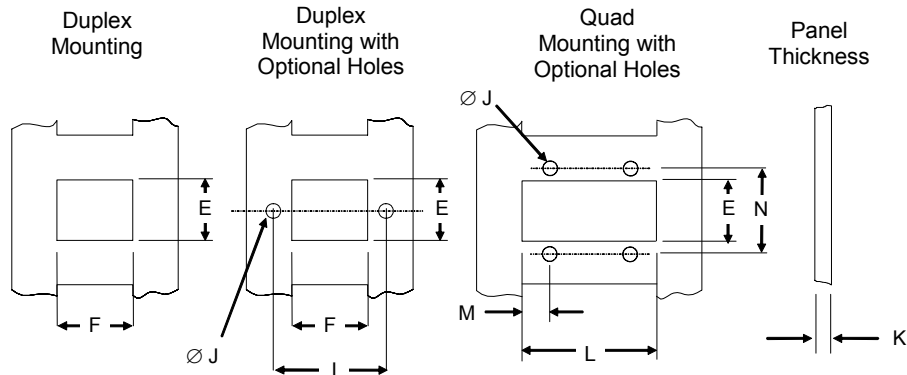

Dimension	Minimum (mm)	Maximum (mm)	Comments
E	9.5	10.0	
F	13.0	13.5	
I	17.9	18.1	Optional
J	2x $\text{Ø } 2.49 \pm 0.10$		Holes Optional
K	1.2	1.7	
L	26.0	26.5	VF only
M	6.45	6.55	Optional, Typ.
N	14.4	14.6	Optional, Typ.

- Panel thickness “K” applies after surface preparation i.e. painting, etc
- Recommended screw size: M2 x 5mm Pan Head
 - Head sizes that can be used w/ lengths below: M2 Pan or 4-40 Socket
 - Slimline Adapter/ screw length: 5.35mm max., 4.5mm min.
 - Slimline VF Adapter/ screw length: no max., 4.5mm min.

Figure 2.3b: Panel Screw Size

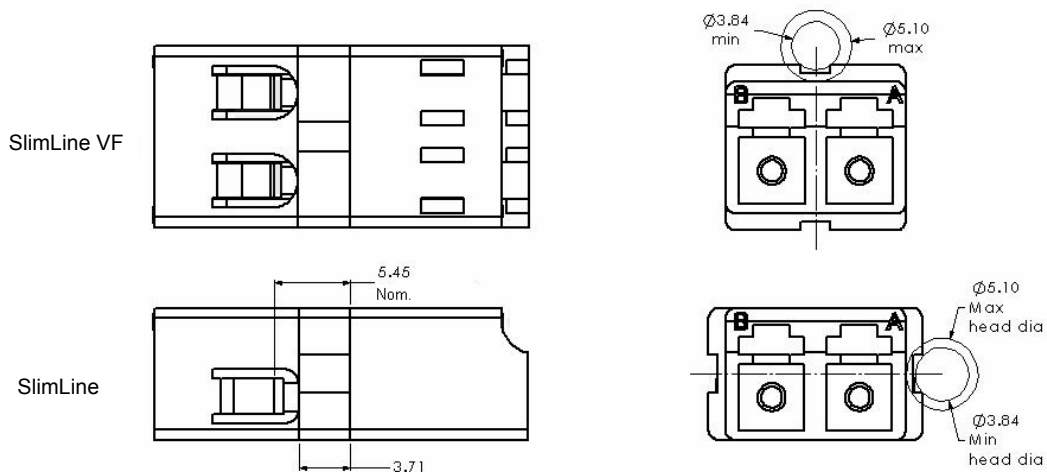

2.4 - LC Adapter Materials

Connector Part	Material	UL 94 Rating	Oxygen Index
Adapter Housing	Engineering Plastic	V-0	50
SM Sleeve	Ceramic	-	-
MM Sleeve	Metal	-	-

2.5 - LC Adapter Specifications for Intermateability

2.5.1 LC Adapter - Senior Side

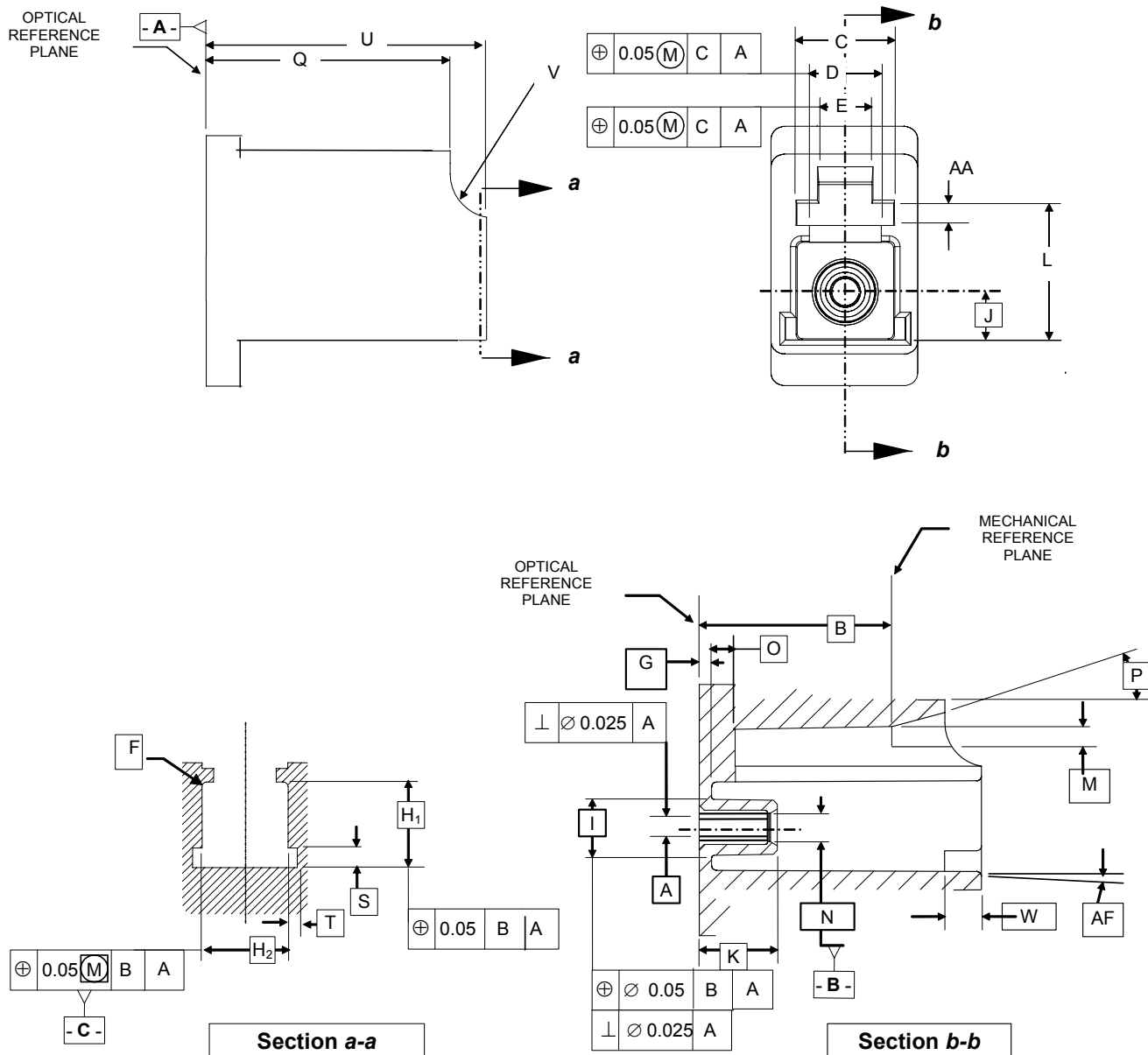

Figure 2.5a - Senior Adapter Interface

Table for Figure 2.5a - Senior Adapter Interface

Dim.	Min. (mm)	Max. (mm)	Notes
A	-	-	1,2
B	9.9	10.0	
C	4.5	-	
D	3.4	3.5	
E	2.6	2.7	
F	0.2	0.3	radius
G	0.6	0.7	
H ₁	4.60	4.75	
H ₂	4.60	4.75	
I	2.87	2.97	diameter
J	2.29		Basic Dimension
K	4.0	4.1	
L	6.6	6.8	
M	1.0	1.1	
N	1.4	1.5	diameter
O	-	1.3	
P	15		degrees, typical
Q	12.6	12.8	
R	-	-	Call-out not used
S	1.0	1.1	
T	0.5	0.6	
U	14.5	14.7	
V	2.2	2.4	radius
W	1.9	-	
X	-	-	Call-out not used
Y	-	-	Call-out not used
Z	-	-	Call-out not used
AA	1.1	1.2	
AF	-	0.2	degrees, 3

Notes:

1. The adapter sleeve is a split (resilient) sleeve and shall be floating within the adapter. The minimum inside diameter of the sleeve is specified by the force required to remove a gage pin from a sleeve. The force required to remove a gage pin from the sleeve shall be 1.0 N to 2.5 N per TIA FOTP 158.
2. A gage pin inserted in the sleeve must be capable of moving freely into a position such that it is coincident with datum *B*.
3. Taper dimension AF is applied to the surfaces associated with dimension/feature H₁ and H₂

2.5.2 LC Adapter - Junior Side

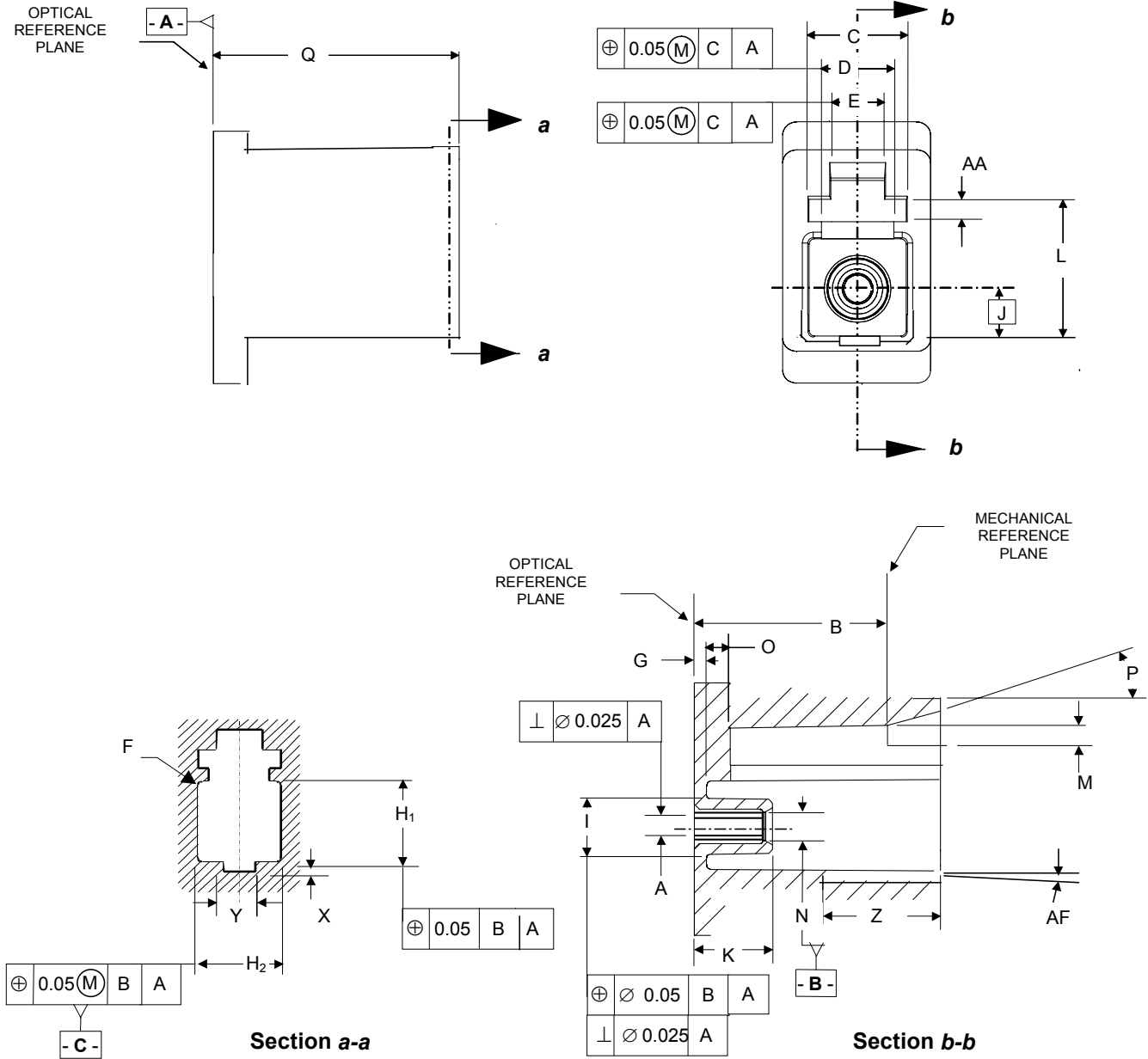

Figure 2.5b - Junior Adapter Interface

Table for Figure 2.5b - Junior Adapter Interface

Dim.	Min. (mm)	Max. (mm)	Notes
A	-	-	1,2
B	9.9	10.0	
C	4.5	-	
D	3.4	3.5	
E	2.6	2.7	
F	0.2	0.3	radius
G	0.6	0.7	
H ₁	4.60	4.75	
H ₂	4.60	4.75	
I	2.87	2.97	diameter
J	2.29		Basic Dimension
K	4.0	4.1	
L	6.6	6.8	
M	1.0	1.1	
N	1.4	1.5	diameter
O	-	1.3	
P	15		degrees, typical
Q	11.0	11.1	
R	-	-	Call-out not used
S	-	-	Call-out not used
T	-	-	Call-out not used
U	-	-	Call-out not used
V	-	-	Call-out not used
W	-	-	Call-out not used
X	0.5	0.6	
Y	1.7	1.8	
Z	5.3	5.4	
AA	1.1	1.2	
AF	-	0.2	degrees, 3

Notes:

1. The adapter sleeve is a split (resilient) sleeve and shall be floating within the adapter. The minimum inside diameter of the sleeve is specified by the force required to remove a gage pin from a sleeve. The force required to remove a gage pin from the sleeve shall be 1.0 N to 2.5 N per TIA FOTP 158.
2. A gage pin inserted in the sleeve must be capable of moving freely into a position such that it is coincident with datum *B*.
3. Taper dimension AF is applied to the surfaces associated with dimension/feature H₁ and H₂

2.6 LC Duplex Adapter Specifications for Intermateability

The standard LC duplex adapter shown here, and the LC Slimline adapter, both conform to the Industry Standard “A” dimension, which is identical to port spacing for LC transceivers.

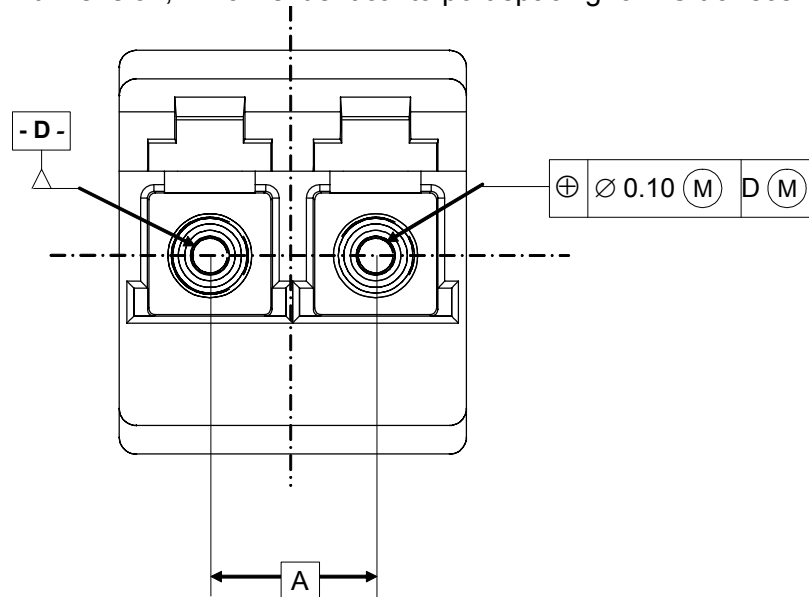

Dim.	Basic Dimension (mm)
A	6.25

Note: Each of the units in the duplex adapter shall comply with all of the dimensions of Figure 2.5a or 2.5b.

Figure 2.6a - Duplex adapter interface

2.7 - LC Adapter Mounting Options

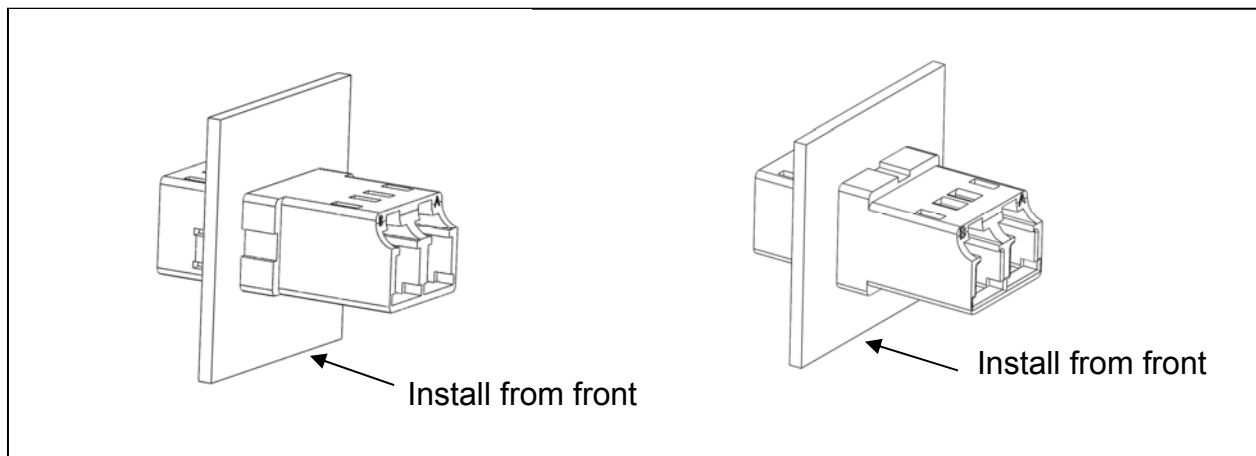

2.8 - LC Adapter Part Identification¹

2.8a - Typical Part Numbers commonly requested

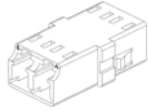
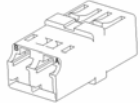
LC/LC Adapter Type		Part No.	Sleeve	Housing Color	Dust Cover ^{2 3}
	SM	OG2LL3-CBW	Ceramic	Blue	White Caps
	SM-APC	OG2LL3-CGW	Ceramic	Green	White Caps
	MM	OG2LL3-MEW	Metal	Beige	White Caps
	MM-Laser Opt	OG2LL3-CQW	Ceramic	Aqua	White Caps
Duplex SlimLine Vertical Flange 	SM	OG2LL4-CBW	Ceramic	Blue	White Caps
	SM-APC	OG2LL4-CGW	Ceramic	Green	White Caps
	MM	OG2LL4-MEW	Metal	Beige	White Caps
	MM-Laser Opt	OG2LL4-CQW	Ceramic	Aqua	White Caps

2.8b - Create a Part w/ the Options below¹

Part No. Format: OG2LL $\frac{X}{a}$ - $\frac{X}{b}$ $\frac{X}{c}$ $\frac{X}{d}$					
		Adapter Type	Alignment Material / Type	Housing Color	Dust Cover Type
a. LC/LC Adapter Type		b. Alignment Sleeve		c. Housing Color	
Duplex SlimLine	OG2LL3	-	C = Ceramic, Zirconia M = Metal, Phos Bronze	B = Blue, SM G = Green, SM-APC E = Beige, MM Q = Aqua, MM-Laser Optimized	
Duplex SlimLine VF	OG2LL4	-			
				d. Dust Cover^{2 3} W = White Caps B = Blue Shutter G = Green Shutter E = Beige Shutter Q = Aqua Shutter K = Black Shutter	
¹ Special order and other options available on request. Please contact your Yazaki salesperson. ² Standard dust cap is 18-mm long. Optional 33-mm dust cap is available on special order. ³ Dust Shutters only available with SlimLine styles, supplied w/ dust caps on opposite end of shutters.					

2.9 - LC Adapter Color Coding (typical)

Application	Adapter Color
Singlemode, SM	Blue
Singlemode – for Angled APC	Green
Multimode, MM	Beige
Multimode, MM, Laser Optimized	Aqua
Multimode, MM, 50/125 um	Beige w/ Black Dust Shutter

2.10 - LC Adapter - Inspection Gauge

Quantity	Item	Part Number
1	LC Adapter Inspection Gauge	OGLGA1-1

- Application:** Precision inspection gauge pin for measuring max. material condition (mmc) of LC Adapter. Excellent for Incoming Inspection.
- For LC Adapters:** For use with all standard LC adapter and receptacle ports, both the senior (front) and junior (rear) side. Duplex connectors must be measured without the duplex yoke. Line-up to port length, see magnified view..
- How to Use:** Insert inspection gauge pin into adapter or receptacle port. Gauge pin should fit into gauge block without sticking or binding. Gauge pin shall be removed from adapter by gravity.
- Material:** Hardened tool steel gauge pin. Anodized aluminum handle.
- Cleaning and Care:** Use Gauge Block preservative and cleaner. Store with a protective dust cap. Use care, do not drop or impact gauge pin.

6.

